



# Big Boy Stove



## This stove was designed with the global south in mind.

The Big Boy biochar stove works with a large variety of biomass. It can work with wood chunks, branches, and logs; corn, wheat, and hemp stalks; coconut shells, and many other materials. This system is an improvement on a conventional burn pit. The flame is enclosed to reduce the fire risk and improve operator safety. Containment of the flames also allows for oxygen control and reduced emissions. This stove is ideal for projects in the global south because no electricity is required for operation. The Big Boy is a highly versatile stove that can be used with many different feedstocks and scaled up or down with ease. There are several variations available to meet specific needs.

**Output:** 50-200 tons/yr depending on size and scale.

\*assuming 10 hr/day runtime, using woody biomass

**Temp. range:** 300-1000° C

**Lead Time:** 90 days

**Fuel:** The Big Boy Stove runs on wood chunks, branches, logs, corn stalks, wheat stalks, hemp stalks, and coconut shells. \*For other feedstocks please inquire.

**Site requirements:** None

**Options:** Please get in touch about your specific needs/projects.

# Overview of Big Boy Stove Variants

---

48



60

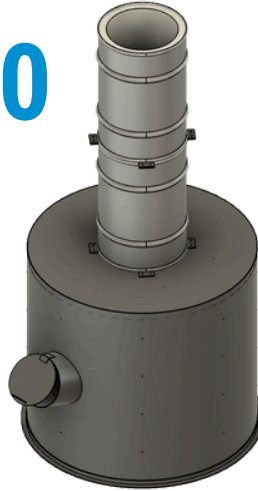

80

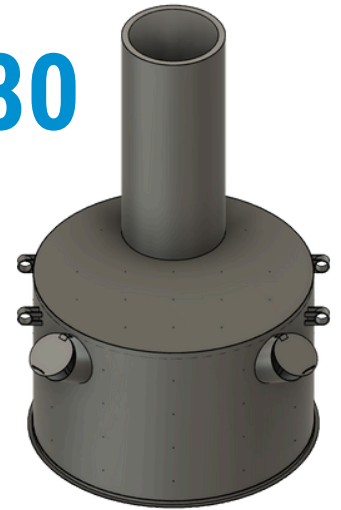

80

Open Feed

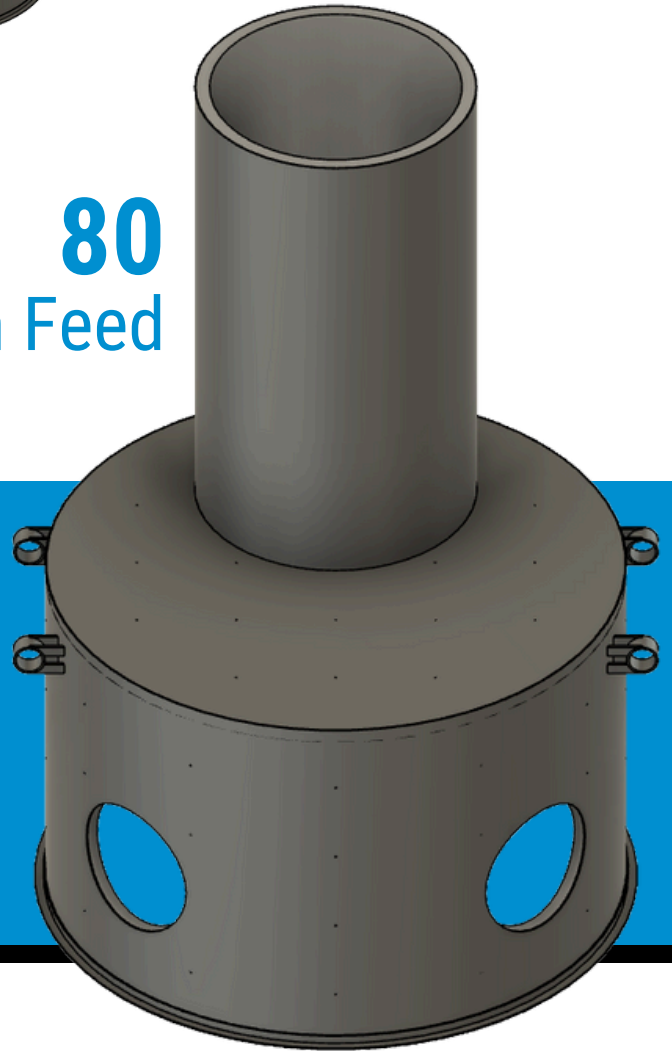

## Contact for more info:

Email: [Zach@HPBiochar.com](mailto:Zach@HPBiochar.com)

Phone: 307-343-0367

Web: [www.HPBiochar.com](http://www.HPBiochar.com)



High Plains Biochar LLC  
108 Howe Rd. Laramie, WY 82070